



TUCSON
Towel Warmer
Chauffe-serviettes
Calentador de toallas

PRODUCT SPECIFICATION SHEET

TUCSON SERIES

TUS-0920600-PC

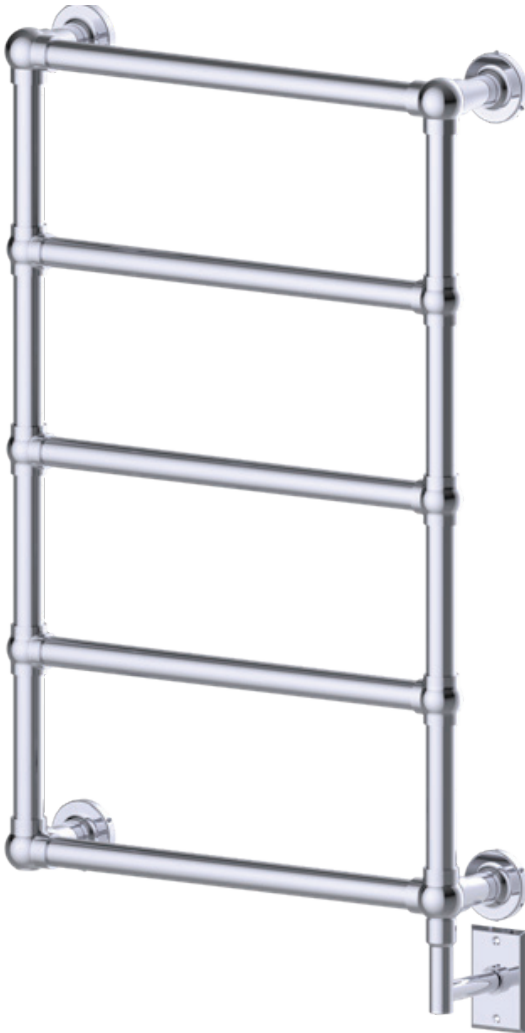

FEATURES

- WALL MOUNTED
 - HARDWIRE INSTALLATION KIT
 - MOUNTING INSTRUCTIONS
 - ALL ELECTRIC AND OIL FILLED
 - COVER PLATES
- TIMERS AVAILABLE SEPARATELY (NOT INCLUDED)

SIZES

- 920x600MM

STOCKED FINISHES

- POLISHED CHROME (PC)
- POLISHED NICKEL (PN)
- BRUSHED NICKEL (BN)



TUS-0920600-BN



TUS-0920600-PN

SEE OVER FOR SPECIFICATION DRAWINGS

Product Code	Finishes	Sizes (mm)		Sizes (Inches)		Output (Watts/BTU)	Element Size	Number of Elements
		Height	Width	Height	Width			
TUS-0920600	PC, BN, PN	920	600	36.62	23.62	208 / 709	300W	5



Distributed by Kartners Bathroom Accessories
toll free number: 1-877-490-3537
website: www.vermontowelwarmers.com

Email: support@vermontowelwarmers.com



Towel Warmers

TUCSON

Towel Warmer
Chauffe-serviettes
Calentador de toallas

PRODUCT SPECIFICATION SHEET

TUS-0920600

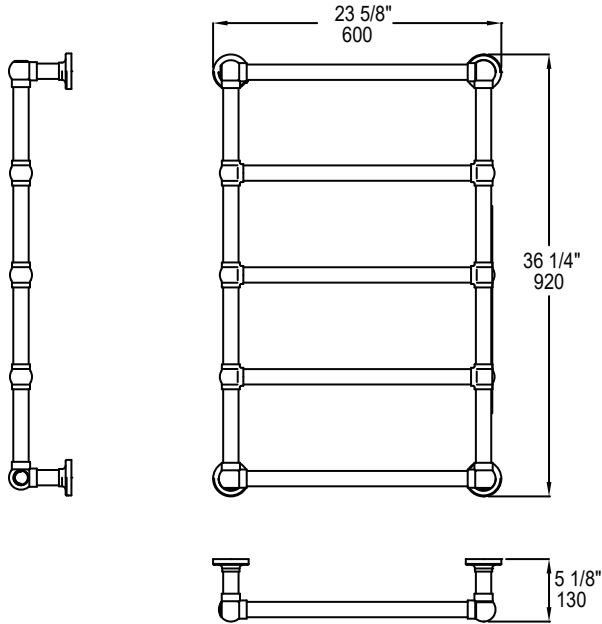

Vernon Towel Warmer Hardwire Kit Round -PC
Code: VTW-HWK-RD-PC

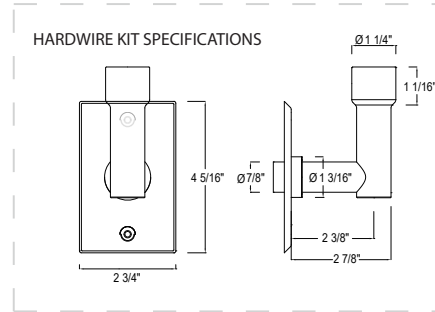

Installation Diagram 1 - Tucson

1. Allen Key
2. Grub screw
3. Wall plate
4. Wall screw
5. Mounting plate
6. Wall plug

TIMERS AVAILABLE



VPT24-1PZ



DDS15-BDZ



Distributed by Kartners Bathroom Accessories
toll free number: 1-877-490-3537
website: www.vernontowelwarmers.com

Email: support@vernontowelwarmers.com